

FULL ASSEMBLY VIEW

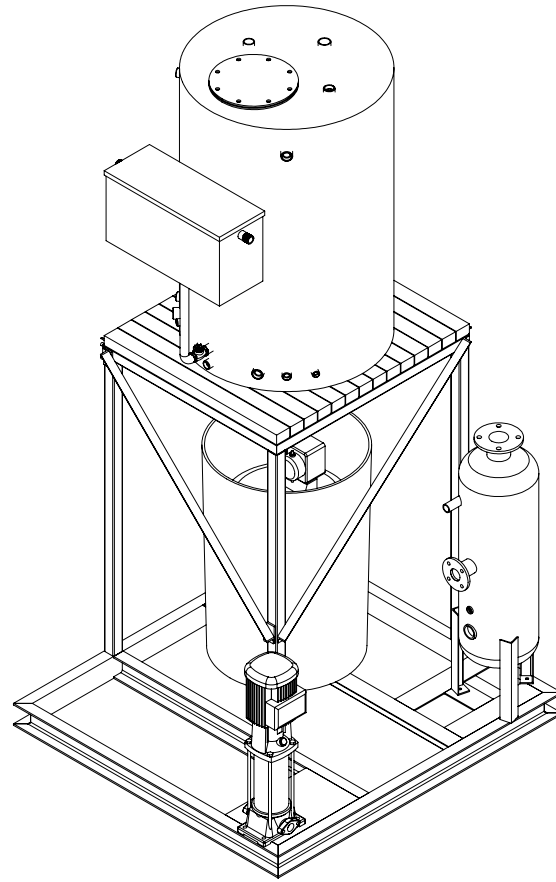

NOTES:
 FULL SKID SUPPLIED HOT DIPPED GALVANIZED
 FEEDWATER TANKS MANUFACTURED FROM DUPLEX STAINLESS STEEL,
 INSULATED AND SIZED FOR MAXIMUM 50% CONDENSATE RETURN
 BLOWDOWN TANK MANUFACTURED IN ACCORDANCE WITH AS1210
 FEED WATER PUMP SIZED FOR MINIMUM 120% OF THE MAXIMUM
 STEAMING CAPACITY OF THE BOILER
 CHEMICAL DOSING AND FILTRATION SIZED FOR 5 DAYS A WEEK AND
 MAXIMUM OF 50 HOURS TOTAL OPERATION EACH WEEK

OVERALL DIMENSIONS FOR TRANSPORTATION

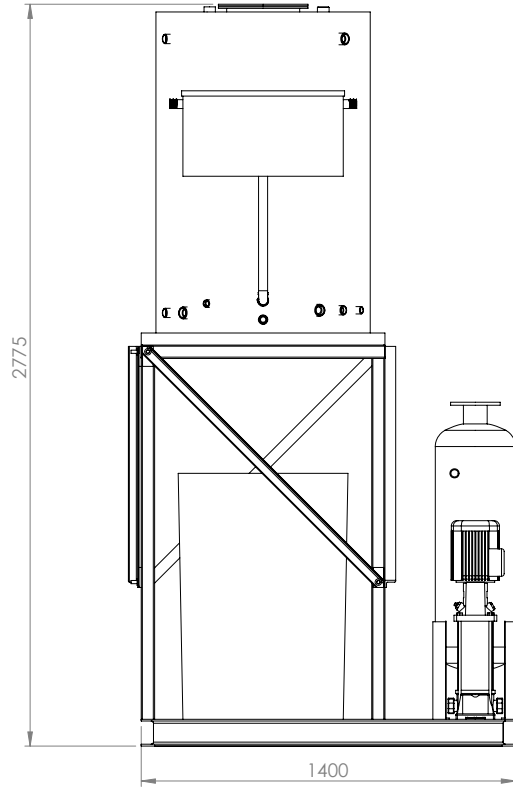
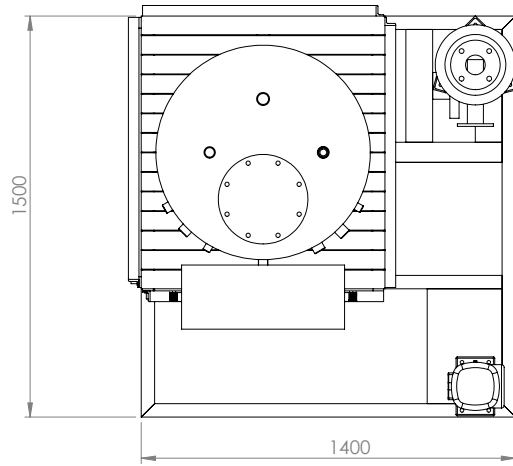
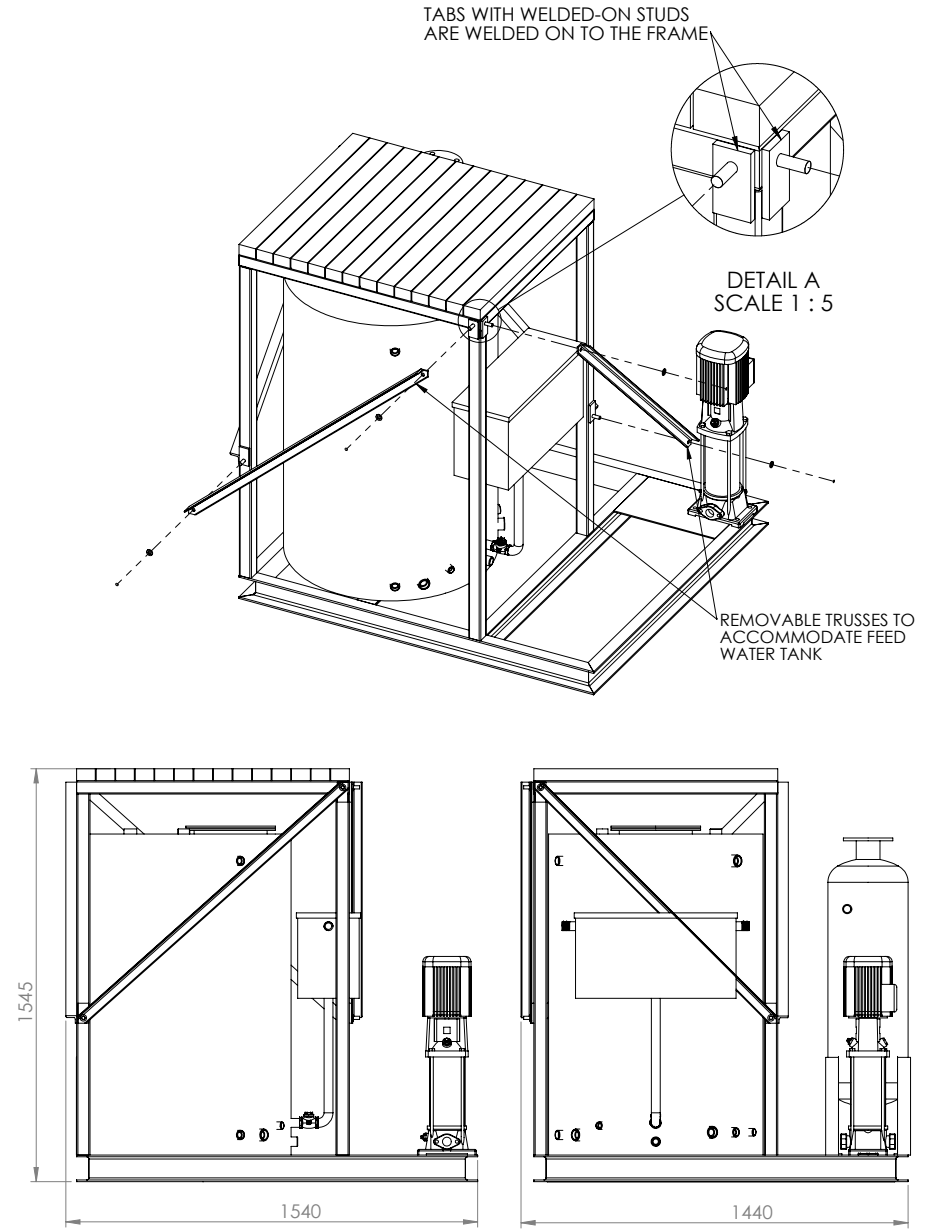

IN THE INTEREST OF CONTINUOUS IMPROVEMENT HUNT BOILERS RESERVES THE RIGHT TO CHANGE THE SPECIFICATIONS OF ITS PRODUCTS WITHOUT PRIOR NOTICE

REV	REVISION NOTE	DATE
A	ORIGINAL ISSUE	06/10/2016
B	INCREASED BASE DIMENSIONS	25/05/2017

REFERENCE DOCUMENTS

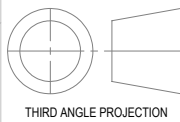

HUNT BOILERS
 A Division of Forbes (Aus:) Pty Ltd

THIS DRAWING WAS PREPARED BY HUNT BOILERS. THE INFORMATION IT CONTAINS IS CONFIDENTIAL AND MUST NOT BE USED, DISCLOSED OR REPRODUCED WITHOUT WRITTEN AUTHORITY.

SCALE: 1:20	DRAWN: V.G
UNITS: mm	DATE: 06/10/2016
SHEET: A3	CHECKED: C.C

DRAWING TITLE:	FULTON SKID FULL ASSEMBLY 100kW-500kW
DRAWING No:	FULTON-SKID-DWG-01

REV: B