

Flue Gas Dilution

CO₂ safe dispersal ventilation



Key Features

- Multi size flue dilution fans
- Ecodesign ErP 2015 compliant
- Easy electrical installation
- Safe operation - internal differential pressure switch for boiler shut off
- Avoid unsightly or expensive discharge flues
- Quiet and efficient
- 1% CO₂ content at outlet
- High levels of corrosion resistance allow use with condensation boilers
- Ecodesign EuP compliant IE2
- Dynamically balanced to DIN ISO 1940 - Grade 6.3

Flue Dilution GBDF & SSDF fans

Their main advantage is avoiding the use of unsightly and expensive flues as shown below. The 1993 Clean Air Act and Institute of Gas Engineers UPE 10/Part 1 (issue 3) Regulations requires that if the products of combustion are dispensed at low level then the CO₂ content must be 1% or less. Airflows' flue dilution range achieves this by introducing fresh air into the boilers discharge flue duct and diluting these flue gases. All fans dynamically balanced to ISO DIN 1940 – Grade 6.3.

Safety

A differential pressure safety switch ensures boiler shutdown in the event of fan failure on blocked flue, the switch consists of a relay circuit which will fall safe and prevent operation of the gas burner under the following conditions.

- Loss of fan air supply (blocked intake / fan motor inlet)
- Stalled fan motor
- Interrupted power supply



Applications

- Flue dilution
- Condensate air handling

The range of dilution fans come in two variations, GBDF for standard atmospheric installations and SSDF for enhanced corrosion resistance especially in use with high condensate content and or condensation boilers. 5 sizes in each range allow selection for industrial and commercial boilers rated up to 650 Kw (2,200,000 Btu).

When the specification of regulations call for stainless steel ducting and when higher efficiency condensate boilers on modular burners are more likely to produce condensation the SSDF range should be selected due to its Aisi 316 stainless steel case construction. Test data in accordance with BS 848 Part 1/ ISO 5801-2007.

Choosing the Correct Size and Type of Fan

Where possible there should be at least 2 metres of flue ducting from the fan to the outlet. To ensure a maximum of 1% CO₂ content at the outlet, the volume flow rate of diluted flue gases necessary for a given boiler can be calculated as follows:

Flow rate in l/sec = 2.69 x rated input of boiler in kW.

Where 2 metres of discharge ducting is not possible then the calculation is:

Flow rate in l/sec = 4.44 x rated input of boiler in kW.

The volume flow rate provided by the fan will depend on the static pressure imposed by the size and length of flue ducting and the number of bends, louvres etc. comprising the installation. The performance table below enables selection of the correct dilution fan based on the flow rate requirement and the fans ability to overcome duct system resistance.

(Note: if LPG or Butane are being used then the factors above should be increased to 3.23 and 5.33 respectively. These flue dilution fans must not be used for any other fuels).

Performance Table at 20°C

Fan size	Static Pressure (Pascals)	Free Air	10	20	30	40	50	60	70	80	90	100	110	120	130	140	160	180	200	225	250	275	300	325	350	375	
GBDF 2 SSDF 2	Volume Litre/s	300	290	280	260	250	240	230	220	190	140	80	40	0													
GBDF 3 SSDF 3	Volume Litre/s	600	580	570	560	540	520	510	500	480	460	440	410	380	320	280	120	40	0								
GBDF 4 SSDF 4	Volume Litre/s	1000	985	970	950	935	920	900	880	860	840	815	780	760	740	710	640	520	340	200	80	0					
GBDF 5 SSDF 5	Volume Litre/s	← NOT SUITABLE DO NOT USE →										1400	1370	1350	1325	1300	1260	1200	1150	1075	975	850	450	200	80	0	
GBDF 6 SSDF 6	Volume Litre/s	← NOT SUITABLE DO NOT USE →															1750	1675	1570	1420	1280	1085	850	625	460		

Dimensions are for guidance only - certified drawings available

Fan size	Units	GBDF 2 SSDF 2	GBDF 3 SSDF 3	GBDF 4 SSDF 4	GBDF 5 SSDF 5	GBDF 6 SSDF 6
Maximum boiler input rating	kw	80	160	270	425	650
Minimum inlet duct diameter	mm	254	305	305	457	457
Minimum inlet louver size	mm	300x300	400x400	400x400	600x600	600x600
Maximum discharge duct diameter	mm	225	275	345	370	457
Minimum discharge grille size	mm	300x300	400x400	450x450	500x500	600x600
Diluted flue gas volume	l/s	215	430	730	1145	1750
Total static pressure loss in system	Pa	70	93	130	160	180
Maximum flue velocity	m/s	5.5	7.3	7.9	10.7	10.7

Fan size	Min. Duct resistance	Max. Line current
GBDF 5 SSDF 5	90 Pa	2.6 Amps
GBDF 6 SSDF 6	180 Pa	2.9 Amps

Minimum duct resistance required on model size 5 and 6 to avoid overloading motors.

Electrical Installation

In all classes of installation, it is essential that the pressure safety switch is connected into the supply circuit of the appliance gas valve so that the gas valve is shut off in the event of a fan failure or flue system blockage. After the fan has been installed and electrically connected, a check should be made to ensure that the pressure safety switch causes the boiler to be switched off when failure or blockage is simulated.

Flue Assistance

The GBDF range can also be used for flue assistance rather than flue dilution (ie: the fan handles all the products of combustion). It is important that the air into the motor side of the fan is ducted from outside the building. The maximum temperature allowed at the inlet of the non drive side of the fan is 110°C (230°F) to maintain acceptable motor bearing and winding temperature. Experience has shown that if a fan is chosen to give a maximum CO₂ concentration of 2% that this maximum temperature will not be exceeded.

Should you wish to use any of our fans purely as an induction fan WITHOUT dilution then the volume rate needed will be :

Flow rate (induction only) in l/sec = 1.35 x rated input of boiler in Kw.

Safety and Ease of Use



Pressure Safety Switch



Easier electrical connections

- Differential pressure safety switch which will activate if the fan stops operating or if the duct system becomes blocked, thus shutting down the boiler.
- 6 or 10 pole plug and socket for easy wiring and installation.

The Range

The Airflow range of Ecodesign ErP 2013/2015 Compliant flue dilution fans is available in 5 sizes to satisfy the dilution needs of industrial and commercial boilers rated up to 650 kW (2,200,000 Btu) input.

Each size is available in standard form (GBDF series) for atmospheric boilers and water heaters of circa 75% efficiency. If excessive corrosion causing the failure of a GBDF series unit is due to the presence of residual condensate, then this will not be covered by our warranty.

Enhanced corrosion resistance versions (SSDF series) with stainless steel fan cases are also available for installation where regulations or the specification calls for stainless steel ducting, and when higher efficiency boilers such as modular designs are likely to produce condensation. SSDF's are therefore recommended for installations where condensation will occur.



Typical Installations

Important when designing and installing a dilution system incorporating Airflow flue dilution fans, attention should be paid to the latest edition of the following standards and guides.

- (i) BS 6644: 2005 Installation of gas fired hot water boilers of rated input between 60 kW and 2 MW.
- (ii) The institute of Gas Engineers and Managers Utilization procedure IGE/UP/10-Edition 3. Installation of Gas Appliances in Industrial & Commercial premises.

The boiler is connected by a vertical flue to a header which is open to the "outside" air at both ends. One end of the header acts as the primary air intake for the dilution air and the other as the discharge. The fan is located on the discharge side of the header duct.

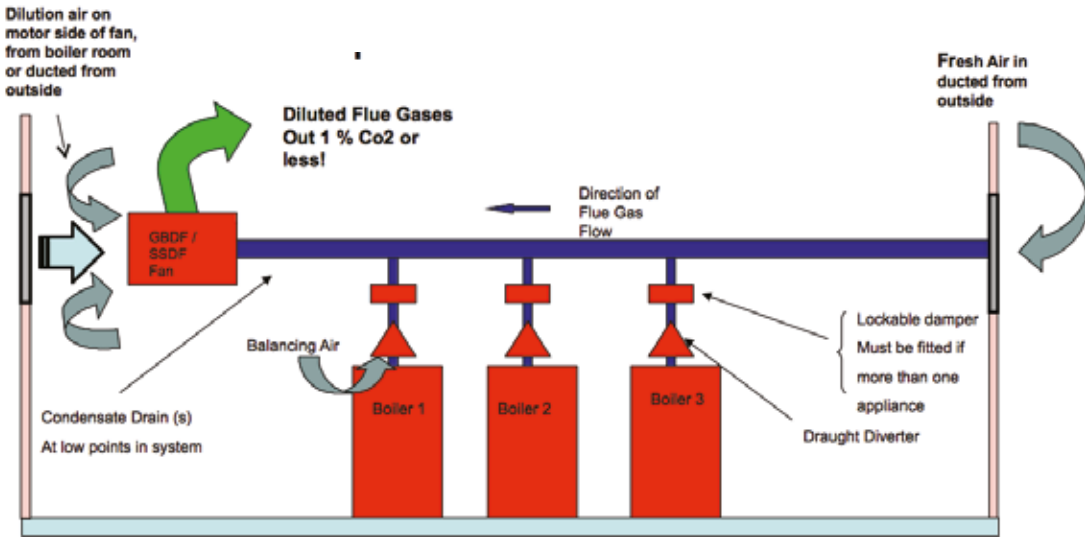

Figure 1.
**GBDF/SSDF
 Flue Dilution Fan
 Multiple Boiler
 Installation**

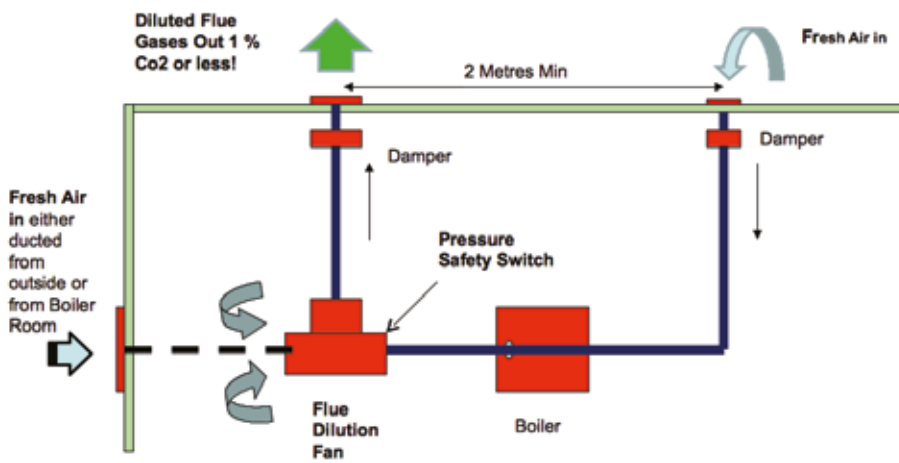
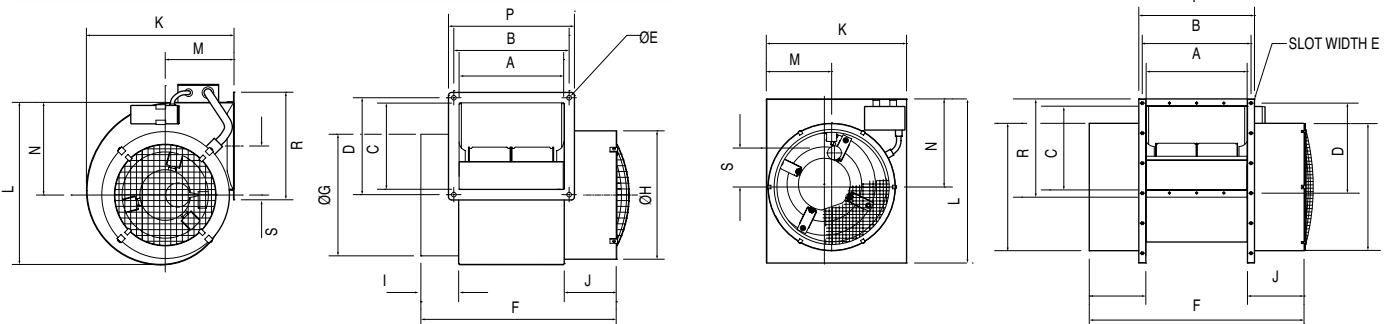

Figure 2.
**GBDF/SSDF Flue
 Dilution Fan
 Single Boiler
 Installation**

Dimensions



Fan size	Weight Kg	Electrical supply V/Ph/Hz	Start current Amps	Full load running current Amps	Motor power Watts	Normal Imp. speed RPM	Max ambient Temp.	Fan size	Minimum clearance
									mm in.
GBDF 2	9.1	230/1/50	1.2	0.64	75	900	40°C	GBDF 2	250 10
SSDF 2	8.8	230/1/50							
GBDF 3	12.1	230/1/50	2.5	1.45	120	860	40°C	GBDF 3	300 12
SSDF 3	12.0	230/1/50							
GBDF 4	22.5	230/1/50	8.4	2.8	335	930	40°C	GBDF 4	460 18
SSDF 4	23.4	230/1/50							
GBDF 5	42.8	415/3/50	12.0*	2.8*	900	940	40°C	GBDF 5	500 20
SSDF 5	44.0	415/3/50	(line)	(MAX)					
GBDF 6	46.7	415/3/50	12.0*	2.9*	900	900	40°C	GBDF 6	630 25
SSDF 6	47.5	415/3/50	(line)	(MAX)					

Fan size	A	B	C	D	E	F	G	H	I	J	K	L	M	N	P	R	S
2	218	238	179	200	9.5	402	251	265	78	106	304	335	140	191	260	222	101
3	250	270	236	257	9.5	440	302	302	78	109	359	394	175	222	294	281	109
4	352	384	263	295	9.5	578	302	340	78	141	408	445	194	256	409	321	121
5	360	386	298	321	7	761	454	454	200	200	500	585	233	314	411	350	145
6	490	517	332	355	7	892	454	454	200	200	500	585	232	336	542	348	145

*Line current
 Minimum clearance for servicing motor and impeller (between motor side inlet and any obstruction)

Call: 01494 560800

Visit: airflow.com



Airflow Developments Limited
 Aidelle House, Lancaster Road,
 Cressex Business Park,
 High Wycombe, Buckinghamshire,
 United Kingdom, HP12 3QP

E-mail: info@airflow.com
 Telephone: +44 (0) 1494 525252
airflow.com

© Airflow Developments Limited. Airflow Developments Limited reserve the right, in the interests of continuous development, to alter specifications without prior notice. All orders are accepted subject to our conditions of sale which are available on request.

